

# FUNCTION GENERATOR KIT

MODEL FG-500K



Assembly and Instruction Manual



## Elenco Electronics, Inc.

## PARTS LIST

Contact Elenco Electronics (address/phone/e-mail is at the back of this manual) if any parts are missing or damaged. **DO NOT** contact your place of purchase as they will not be able to help you.

### RESISTORS

Qty	Symbol	Description	Color Code	Part #
<input type="checkbox"/> 1	R6	200Ω 5% ¼W	red-black-brown-gold	132000
<input type="checkbox"/> 1	R1	620Ω 5% ¼W	blue-red-brown-gold	136200
<input type="checkbox"/> 1	R5	3.9kΩ 5% ¼W	orange-white-red-gold	143900
<input type="checkbox"/> 1	R7	8.2kΩ 5% ¼W	gray-red-red-gold	148200
<input type="checkbox"/> 1	R8	10kΩ 5% ¼W	brown-black-orange-gold	151000
<input type="checkbox"/> 1	R4	22kΩ 5% ¼W	red-red-orange-gold	152200
<input type="checkbox"/> 1	R9	100kΩ 5% ¼W	brown-black-yellow-gold	161000
<input type="checkbox"/> 1	R2	10kΩ Potentiometer		192531
<input type="checkbox"/> 1	R3	100kΩ Potentiometer		192612

### CAPACITORS

Qty	Symbol	Value	Description	Part #
<input type="checkbox"/> 1	C6	820pF (821) 10%	Discap	228210
<input type="checkbox"/> 1	C5	.01μF (103) 10%	Mylar	241017
<input type="checkbox"/> 1	C4	.1μF (104) 10%	Mylar	251017
<input type="checkbox"/> 1	C3	1μF 50V	Electrolytic (Lytic)	261047
<input type="checkbox"/> 3	C2, C7, C8	10μF 16V	Electrolytic (Lytic)	271015
<input type="checkbox"/> 1	C1	100μF 16V	Electrolytic (Lytic)	281044
<input type="checkbox"/> 1	C9	1,000μF 16V	Electrolytic (Lytic)	291044

### SEMICONDUCTORS

Qty	Symbol	Value	Description	Part #
<input type="checkbox"/> 1	U1	XR-2206	Integrated Circuit	332206

Qty	Description	Part #	Qty	Description	Part #
<input type="checkbox"/> 1	PC Board	511003	<input type="checkbox"/> 2	Binding Post Yellow	625034
<input type="checkbox"/> 2	DPDT Switch PC Mount	541009	<input type="checkbox"/> 4	Screw 4-40 x ¼" Phillips	641433
<input type="checkbox"/> 1	Switch Rotary 2p6pos	542207	<input type="checkbox"/> 3	Hex Nut 7mm	644101
<input type="checkbox"/> 1	Battery Snap	590098	<input type="checkbox"/> 1	Hex Switch Nut 9mm	644102
<input type="checkbox"/> 1	Top Panel	614111	<input type="checkbox"/> 2	Flat Washer 8mm x 14mm	645101
<input type="checkbox"/> 3	Knob	622009	<input type="checkbox"/> 1	Flat Washer 9mm	645103
<input type="checkbox"/> 1	Jack Ear Phone with Nut	622130	<input type="checkbox"/> 1	16-pin IC Socket	664016
<input type="checkbox"/> 1	Case	623003LP	<input type="checkbox"/> 1	Handle	666600
<input type="checkbox"/> 2	Spacer 5/8"	624432	<input type="checkbox"/> 2"	Weather Strip	790007
<input type="checkbox"/> 1	Binding Post Black	625031	<input type="checkbox"/> 1.5'	Black Wire 22ga.	814120
<input type="checkbox"/> 3	Nut Binding Post	625031HN	<input type="checkbox"/> 1	Solder	9ST4
<input type="checkbox"/> 3	Lockwasher Binding Post	625031LW			

## PARTS IDENTIFICATION

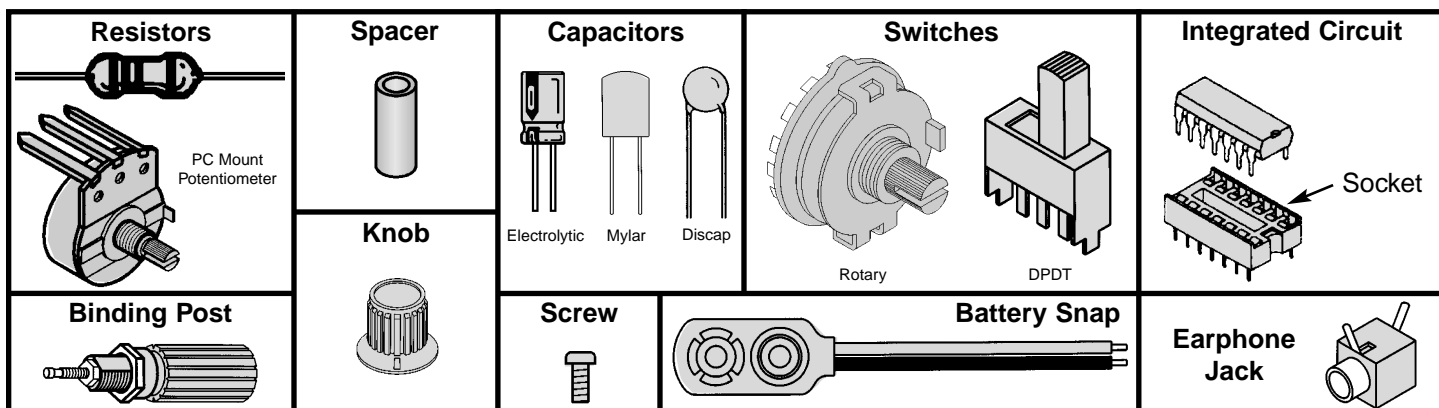

## IDENTIFYING RESISTOR VALUES

Use the following information as a guide in properly identifying the value of resistors.

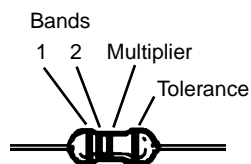

BAND 1 1st Digit	
Color	Digit
Black	0
Brown	1
Red	2
Orange	3
Yellow	4
Green	5
Blue	6
Violet	7
Gray	8
White	9

BAND 2 2nd Digit	
Color	Digit
Black	0
Brown	1
Red	2
Orange	3
Yellow	4
Green	5
Blue	6
Violet	7
Gray	8
White	9

Multiplier	
Color	Multiplier
Black	1
Brown	10
Red	100
Orange	1,000
Yellow	10,000
Green	100,000
Blue	1,000,000
Silver	0.01
Gold	0.1

Resistance Tolerance	
Color	Tolerance
Silver	$\pm 10\%$
Gold	$\pm 5\%$
Brown	$\pm 1\%$
Red	$\pm 2\%$
Orange	$\pm 3\%$
Green	$\pm .5\%$
Blue	$\pm .25\%$
Violet	$\pm .1\%$

## IDENTIFYING CAPACITOR VALUES

Capacitors will be identified by their capacitance value in pF (picofarads), nF (nanofarads) or  $\mu\text{F}$  (microfarads). Most capacitors will have their actual value printed on them. Some capacitors may have their value printed in the following manner.



Multiplier	For the No.	0	1	2	3	4	5	8	9
		Multiply By	1	10	100	1k	10k	100k	.01

The above value is  $10 \times 1,000 = 10,000\text{pF}$  or  $.01\mu\text{F}$

The letter K indicates a tolerance of  $\pm 10\%$

The letter J indicates a tolerance of  $\pm 5\%$

Note: The letter "R" may be used at times to signify a decimal point; as in 3R3 = 3.3

## INTRODUCTION

Assembly of your FG-500 Function Generator will prove to be an exciting project and give much satisfaction and personal achievement. The FG-500 contains a complete function generator capable of producing sine, square and triangle wave forms. The frequency of this generator can be continuously varied from 1Hz to 1MHz in 6 steps. A fine frequency control makes selection of any frequency in between easy. The amplitude of the wave forms are adjustable from 0 to 3Vpp. This complete function generator system is suitable for experimentation and applications by the student. The entire function generator is comprised of a single XR-2206 monolithic IC and a limited number of passive circuit components.

## SPECIFICATIONS

### OUTPUT:

- Waveforms: Sine, Triangle, Square
- Impedance:  $600\Omega \pm 10\%$ .
- Frequency: 1Hz - 1MHz in 6 decade steps with variable ranges.

### SINE WAVE:

- Amplitude: 0 - 3Vpp at 9VDC input.
- Distortion: Less than 1% (at 1kHz).
- Flatness:  $\pm 0.05\text{dB}$  1Hz - 100kHz.

### SQUARE WAVE:

- Amplitude: 8V (no load) at 9VDC input.
- Rise Time: Less than 50ns (at 1kHz).
- Fall Time: Less than 30ns (at 1kHz).
- Symmetry: Less than 5% (at 1kHz).

### TRIANGLE WAVE:

- Amplitude: 0 - 3Vpp at 9VDC input.
- Linearity: Less than 1% (up to 100kHz).

### POWER REQUIREMENTS:

- Standard 9V Battery or 9V to 18VDC at input.

### OPERATING TEMPERATURE:

- 0°C TO 50°C.

# CONSTRUCTION

## Introduction

The most important factor in assembling your FG-500K Function Generator Kit is good soldering techniques. Using the proper soldering iron is of prime importance. A small pencil type soldering iron of 25 - 40 watts is recommended. **The tip of the iron must be kept clean at all times and well tinned.**

## Safety Procedures

- Wear eye protection when soldering.
- Locate soldering iron in an area where you do not have to go around it or reach over it.
- **Do not hold solder in your mouth.** Solder contains lead and is a toxic substance. Wash your hands thoroughly after handling solder.
- Be sure that there is adequate ventilation present.

## Assemble Components

In all of the following assembly steps, the components must be installed on the top side of the PC board unless otherwise indicated. The top legend shows where each component goes. The leads pass through the corresponding holes in the board and are soldered on the foil side.

**Use only rosin core solder of 63/37 alloy.**

**DO NOT USE ACID CORE SOLDER!**

## What Good Soldering Looks Like

A good solder connection should be bright, shiny, smooth, and uniformly flowed over all surfaces.

1. Solder all components from the copper foil side only. Push the soldering iron tip against both the lead and the circuit board foil.

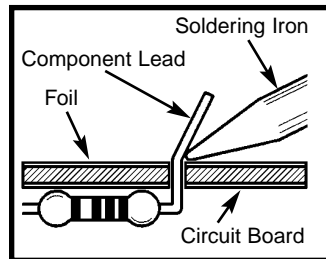

2. Apply a small amount of solder to the iron tip. This allows the heat to leave the iron and onto the foil. Immediately apply solder to the opposite side of the connection, away from the iron. Allow the heated component and the circuit foil to melt the solder.

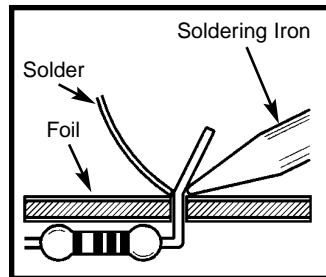

3. Allow the solder to flow around the connection. Then, remove the solder and the iron and let the connection cool. The solder should have flowed smoothly and not lump around the wire lead.

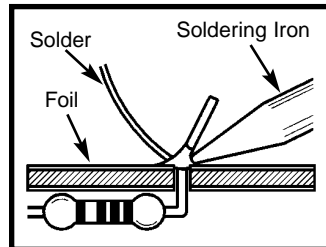

4. Here is what a good solder connection looks like.

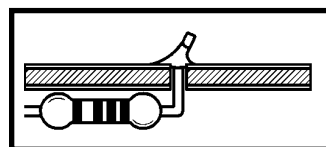

## Types of Poor Soldering Connections

1. **Insufficient heat** - the solder will not flow onto the lead as shown.

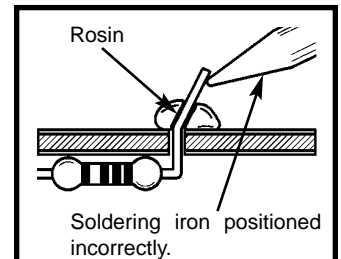

2. **Insufficient solder** - let the solder flow over the connection until it is covered. Use just enough solder to cover the connection.

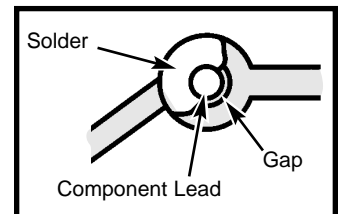

3. **Excessive solder** - could make connections that you did not intend to between adjacent foil areas or terminals.

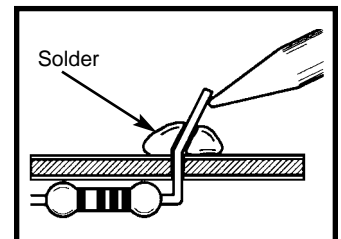

4. **Solder bridges** - occur when solder runs between circuit paths and creates a short circuit. This is usually caused by using too much solder. To correct this, simply drag your soldering iron across the solder bridge as shown.

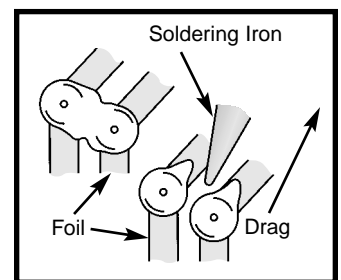

# ASSEMBLE COMPONENTS TO THE PC BOARD

Care must be given to identifying the proper components and in good soldering habits. Refer to the soldering tips section in this manual before you begin installing the components. Place a check mark in the box  after each step is complete.

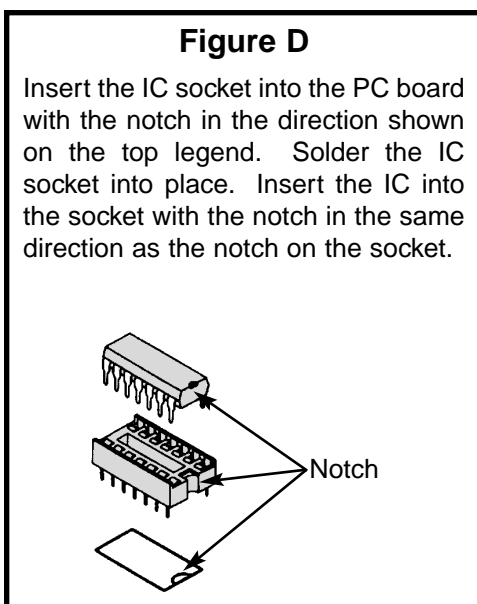
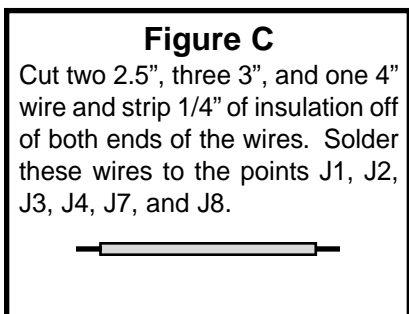
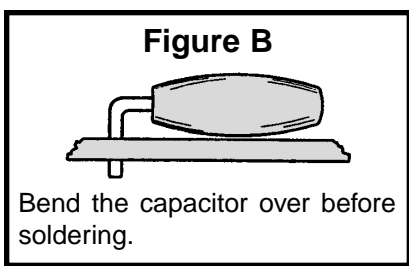
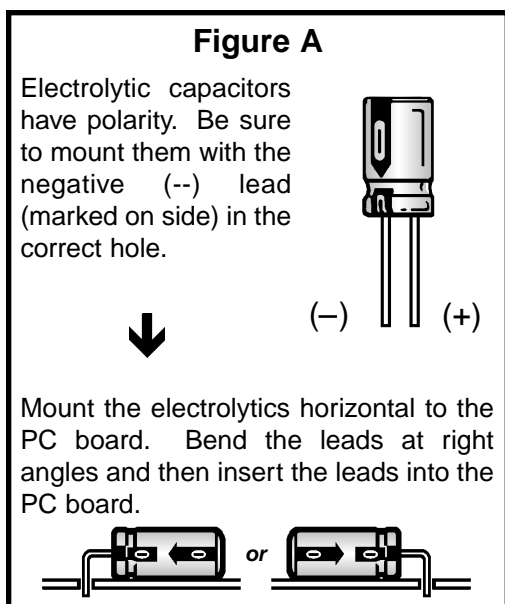
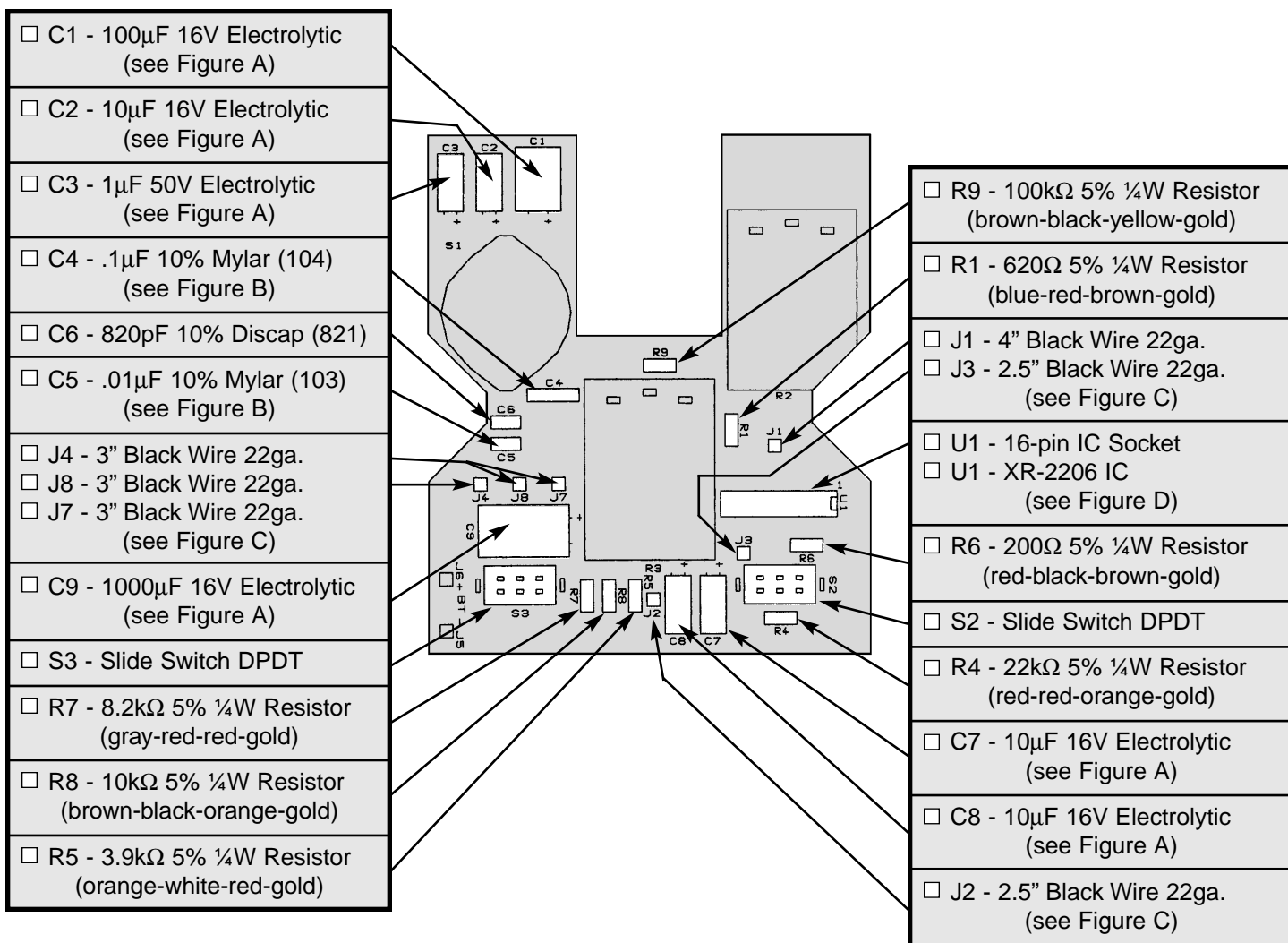

## ASSEMBLE COMPONENTS TO THE PC BOARD

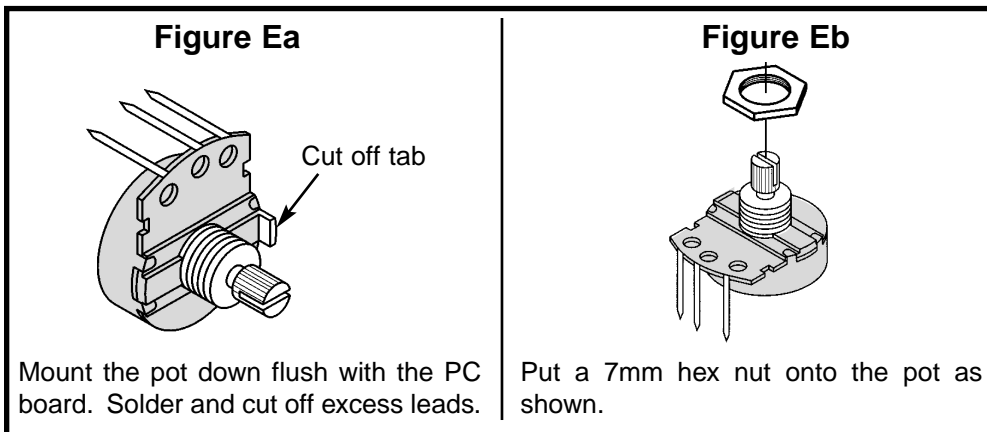
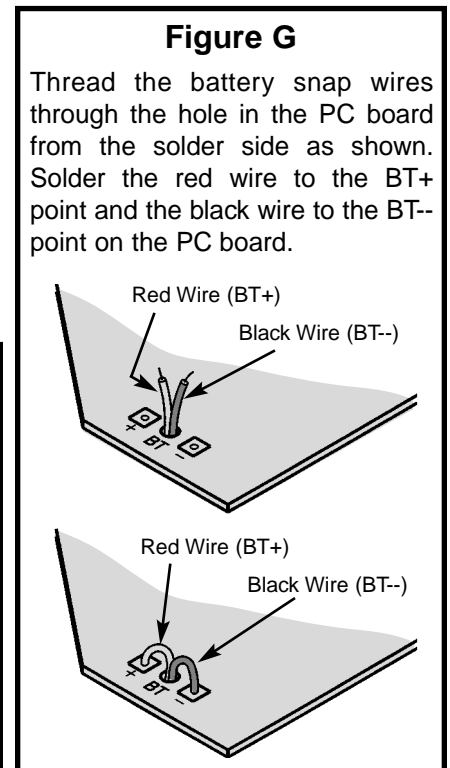
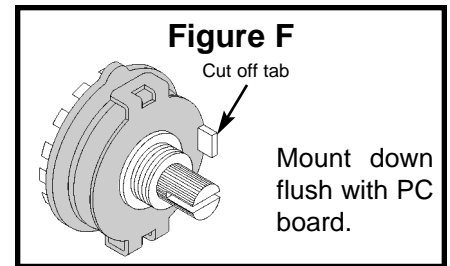
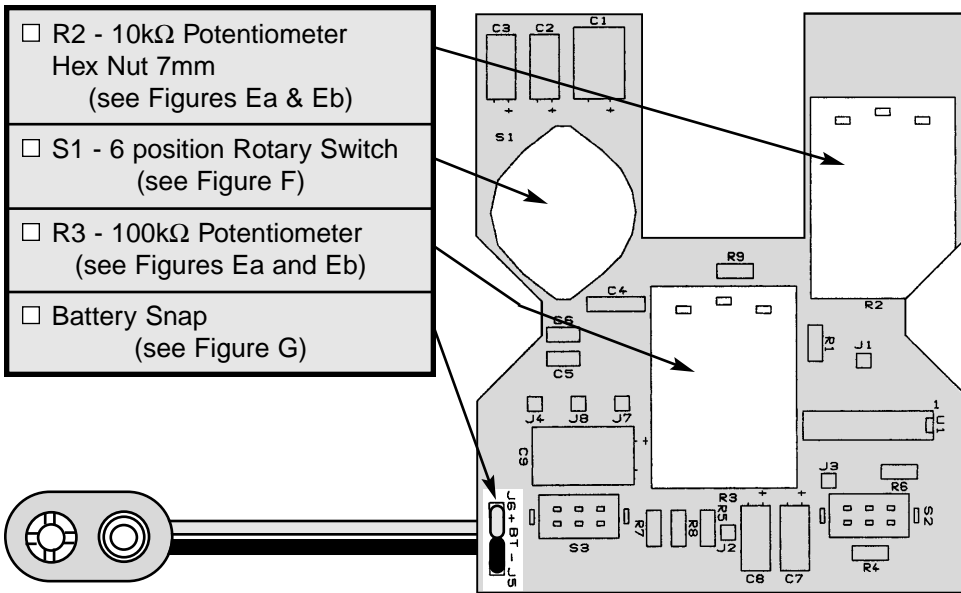

## INSTALL COMPONENTS TO FRONT PANEL

- Install the jack to the panel with the side lug facing the direction shown in Figure H. Fasten the jack in place with the round nut from the front side of the panel.

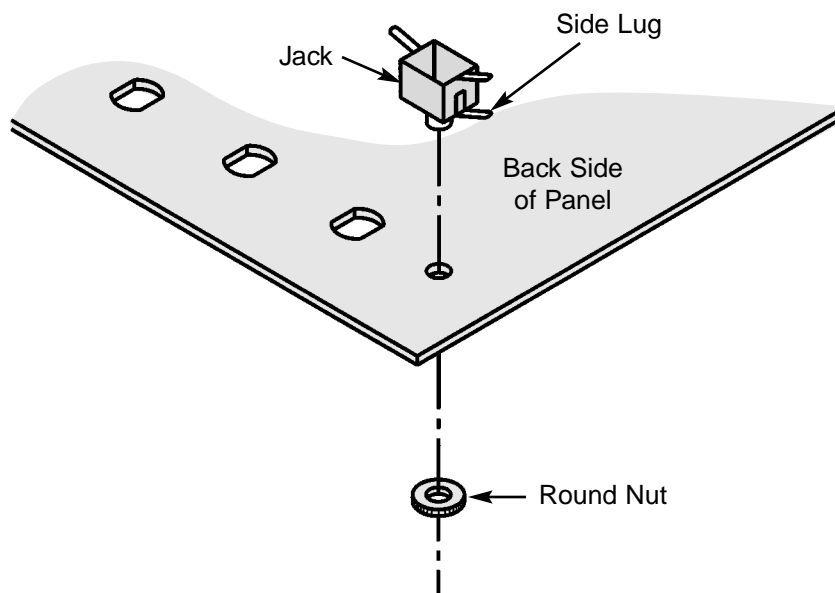

**Figure H**

- Install the colored binding posts to the panel as shown in Figure I. Use the hardware shown in the figure. Make sure that the small nut is tight.

## WIRING (See Figure J and Ja)

- Solder the wire from hole J1 on the PC board to the first yellow binding post as shown.
- Solder the wire from hole J2 on the PC board to the second yellow binding post as shown.
- Solder the wire from hole J3 on the PC board to the black binding post as shown.
- Solder the wire from hole J4 on the PC board to the lower lug (A) of the jack as shown.
- Solder the wire from hole J7 on the PC board to the upper left lug (C) on the jack as shown.
- Solder the wire from hole J8 on the PC board to the upper right lug (B) on the jack as shown.

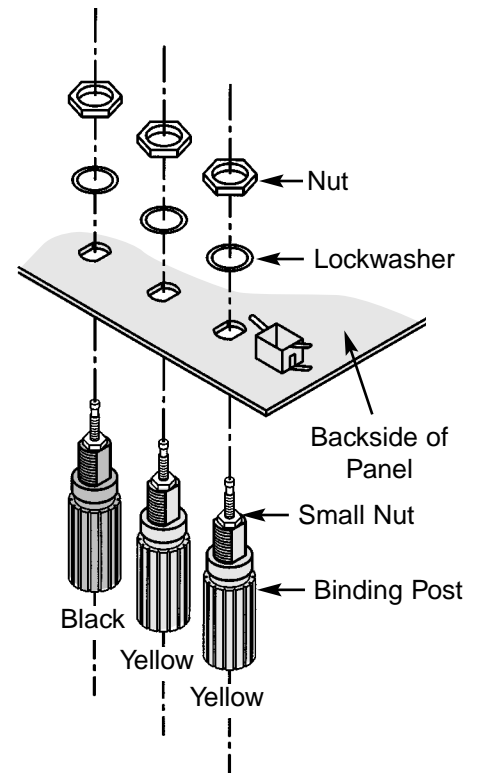

Figure I

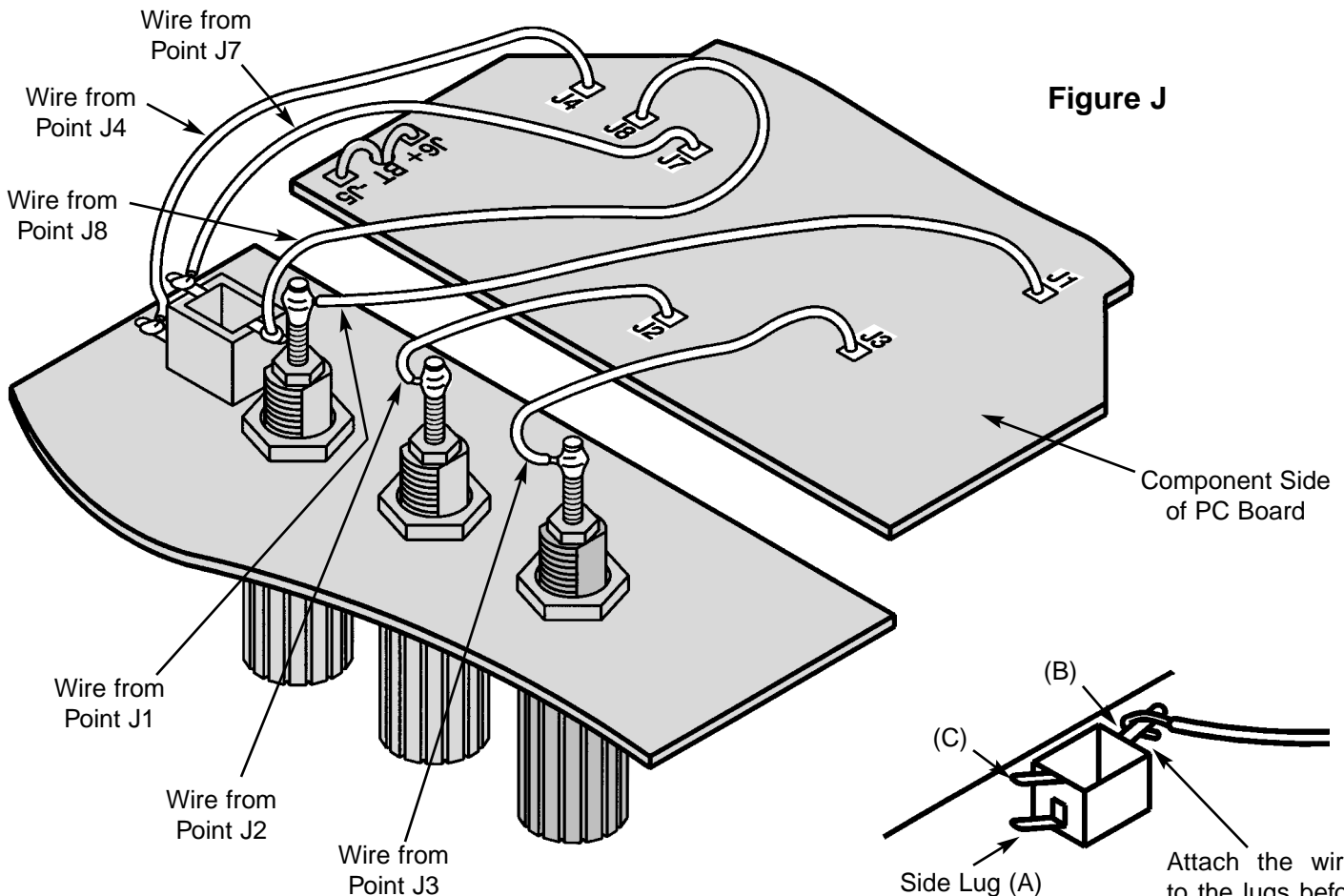

Figure J

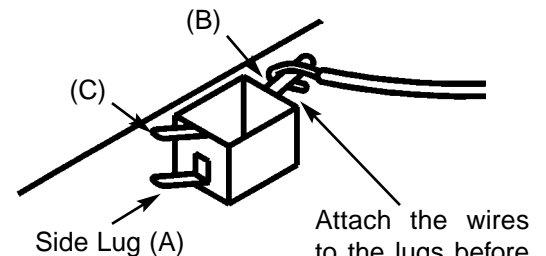
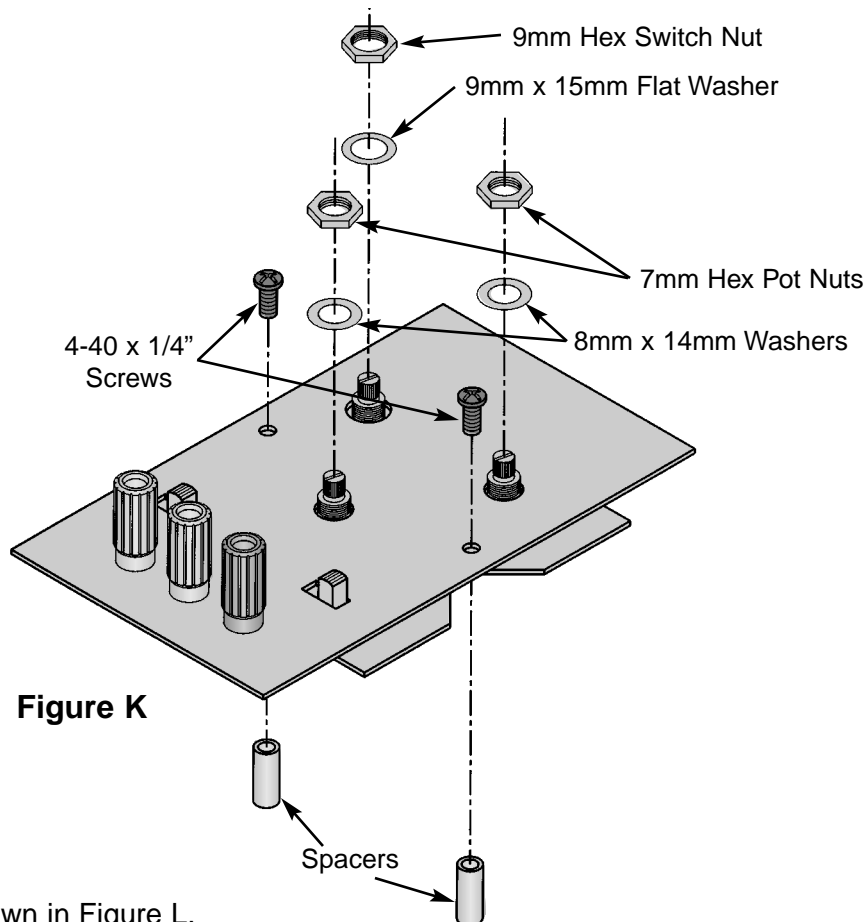

Figure JA

## FINAL ASSEMBLY

- Fit the panel onto the PC board assembly. Be sure that all switches and pots come through the holes in the panel as shown in Figure K.
- Place the washers onto their locations as shown in Figure K, being careful to check the sizes. Then, tighten the hex nuts onto the potentiometers and rotary switch noting their size as shown in Figure K. Finally, fasten the spacers onto the top panel with two 4-40 x 1/4" black screws.



- Install the handle as shown in Figure L.
- Cut two pieces of weather stripping. Remove the protective backing and place a piece of weather strip on the top panel in the location shown in Figure L. Then, place the other piece on the case in the location shown.

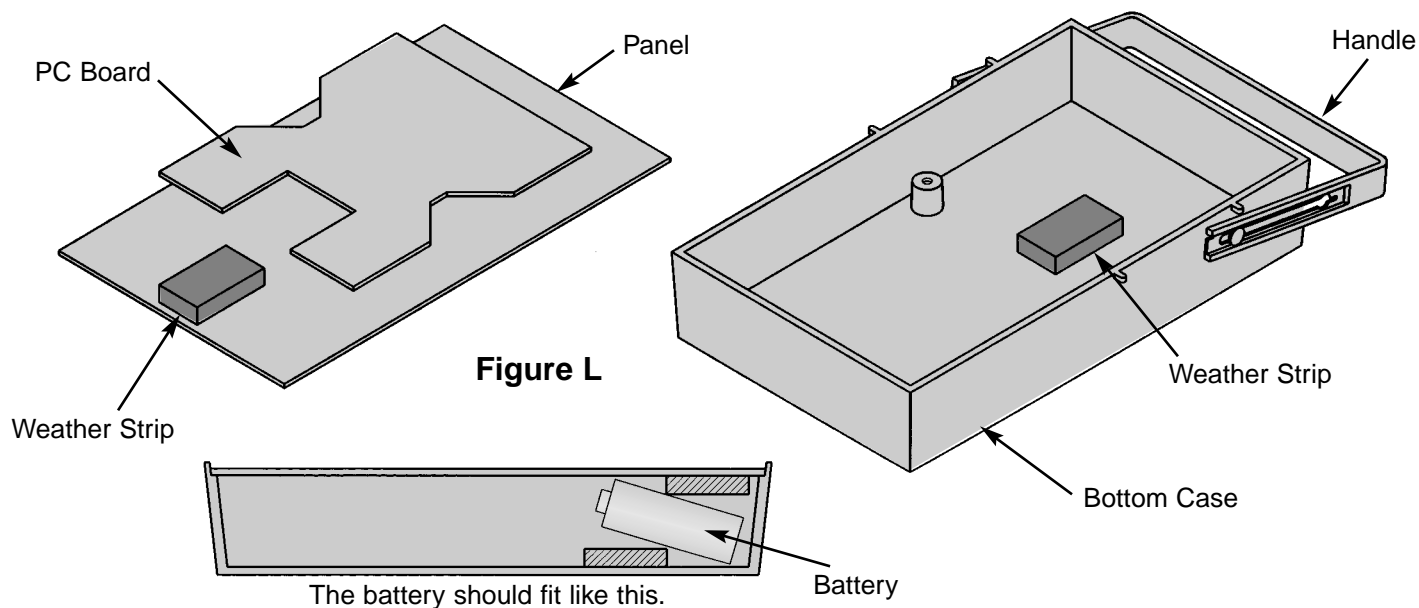

- Attach the battery snap to the battery. Insert the PC board assembly with the panel and battery into the case (as shown in Figure L). Insert two 4-40 x 1/4" screws into the bottom case in positions shown in Figure M and tighten in place.
- Turn the shafts on the two potentiometers and rotary switch fully counter-clockwise. Push the three knobs onto the shafts so that the line on the knob is on the point as shown in Figure N.

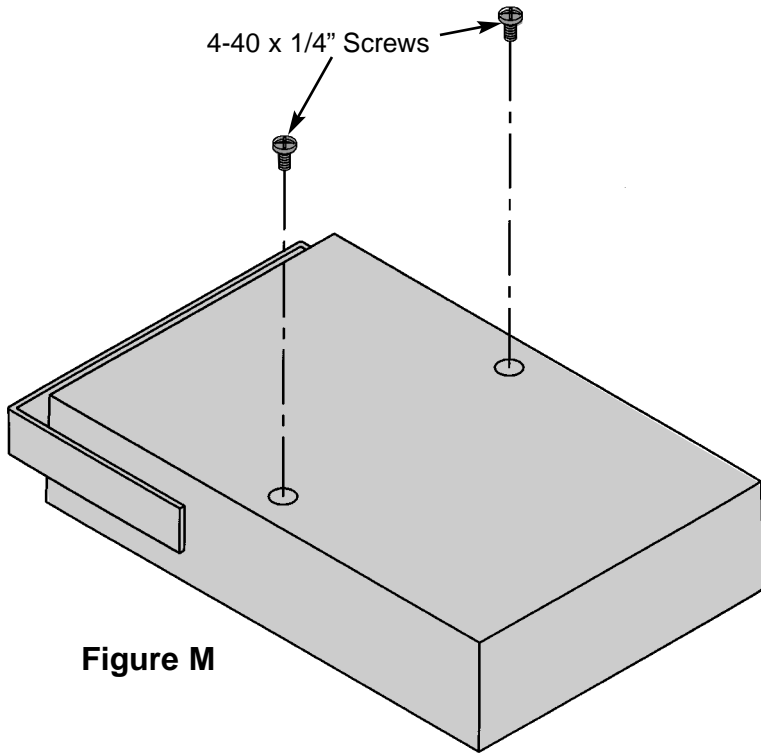

**Figure M**

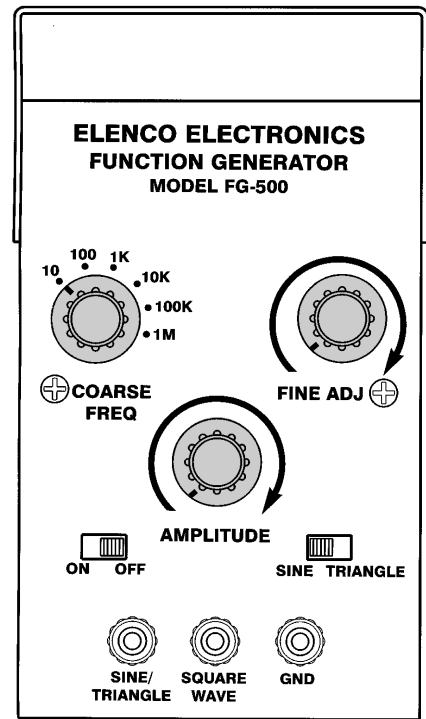

**Figure N**

## TESTING THE FG-500 FUNCTION GENERATOR

The unit may be tested by following the 4 steps listed below. Should any of these tests fail, refer to the Troubleshooting Guide.

1) Set the switches and pots as follows:

On/Off	On
Range	10
Frequency	Maximum (clockwise)
Amplitude	Maximum (clockwise)
Sine/Triangle	Set Sine/Triangle switch to Sine position

In each of the following steps, start with the switch and pots as shown on the previous page.

## **2) OUTPUT WAVEFORMS**

Connect an oscilloscope probe to the square wave output. You should see about 8V peak to peak square wave of a little over 15Hz. Connect the oscilloscope probe to the sine/triangle wave output. You should see a sine wave of approximately 3V peak to peak or greater. Set the Sine/Triangle switch to the Triangle wave position. You should see a triangle waveform of approximately 3V peak to peak or greater. In both sine and triangle waves, the frequency is also a little over 15Hz.

## **3) FREQUENCY CONTROLS**

6 range settings, vary the FREQUENCY pot from max to min and check that the frequency varies according to Table 1 on page 11 or greater.

## **4) AMPLITUDE CONTROLS**

Set the switch and pots as in Step 1. Connect the oscilloscope to the sine/triangle wave output and vary the AMPLITUDE pot. The sine wave amplitude should vary from near zero to approximately 3V peak to peak or greater.

---

# **TROUBLESHOOTING GUIDE**

## **A) NO SINE/TRIANGLE OR SQUARE WAVE OUTPUT**

- 1) Check the soldering on switch S3.
- 2) Check battery and battery snap.
- 3) Check jack.
- 4) Check the soldering on IC U1.
- 5) Check for +9V on IC1 pin 4.
- 6) Check that U1 is not installed backwards.
- 7) Check all of the values and soldering on R1, R2, R3, R4, R5, R7, R8, R9, C8, and C9.

## **B) WRONG FREQUENCY ON ANY RANGE SETTING**

- 1) This indicates a wrong value capacitor in the bad range position.

## **C) SINE/TRIANGLE SWITCH DOESN'T WORK**

- 1) Check the soldering on switch S2 and R6.
- 2) Check the value of R6.
- 3) Check pin 13 and 14 of U1.

## **D) AMPLITUDE CONTROL DOESN'T WORK**

- 1) Check the soldering on R3, R7, R8, R4 and R9.
- 2) Check the values of the above mentioned components.

## **E) FREQUENCY CONTROL DOESN'T WORK**

- 1) Check the soldering on R1 and R2.
- 2) Check the values of the above two resistors.

## FUNCTIONAL DESCRIPTION

The FG-500 is a function generator integrated circuit capable of producing high quality sine, triangle, and square waves of high stability and accuracy. A picture of each waveform is shown below:

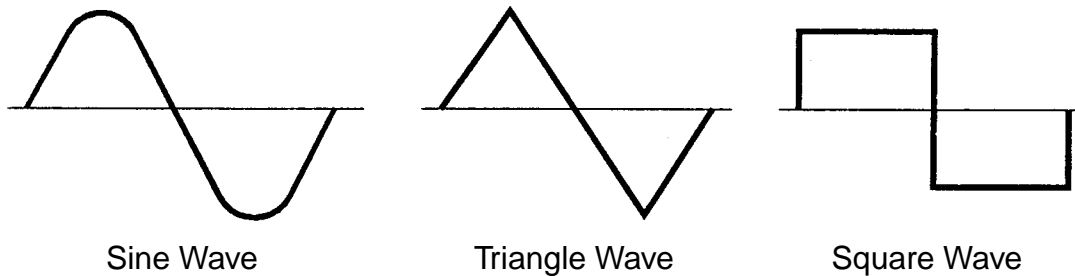

Sine Wave

Triangle Wave

Square Wave

## THEORY OF OPERATION

The heart of the FG-500 Function Generator is the XR-2206 monolithic function generator integrated circuit. The XR-2206 is comprised of four main functional blocks as shown in the functional block diagram (Figure 1). They are:

- A Voltage Controlled Oscillator (VCO)
- An Analog Multiplier and Sine-shaper
- Unity Gain Buffer Amplifier
- A set of current switches

The VCO actually produces an output frequency proportional to an input current, which is produced by a resistor from the timing terminals to ground. The current switches route one of the currents to the VCO to produce an output frequency. Which timing pin current is used, is controlled by the FSK input (pin 9). In the FG-500, the FSK input is left open, thus only the resistor on pin 7 is used. The frequency is determined by this formula:

$$f_o = 1/RC \text{ Hz}$$

- where
- $f_o$  is the frequency in Hertz
  - R is the resistance at pin 7 in Ohms
  - C is the capacitance across pin 5 and 6 in Farads

Note that frequency is inversely proportional to the value of RC. That is, the higher the value of RC, the smaller the frequency.

The resistance between pins 13 and 14 determine the shape of the output wave on pin 2. No resistor produces a triangle wave. A 200Ω resistor produces a sine wave.

## FUNCTIONAL BLOCK DIAGRAM

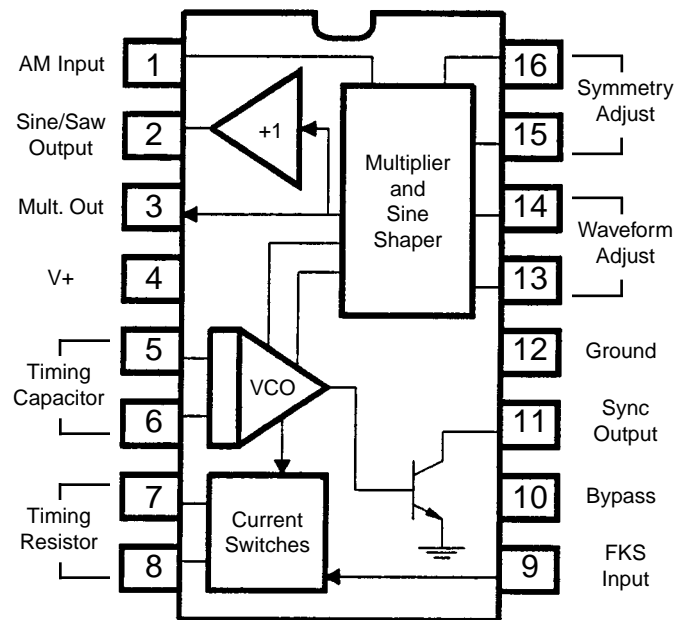

Figure 1

---

## CONTROLS

### RANGE SWITCHES

Six ranges of frequency are provided by the range switch as shown in Table 1.

POSITION	TYPICAL FREQUENCY RANGE
1	1Hz - 15Hz
2	10Hz - 150Hz
3	100Hz - 1.5kHz
4	1kHz - 15kHz
5	10kHz - 150kHz
6	100kHz - 1MHz

**Table 1**

### SINE/TRIANGLE SWITCH

This SINE/TRIANGLE Switch selects the waveform, sine wave or triangle wave, sent to the SINE/TRIANGLE output terminal.

### FREQUENCY MULTIPLIER

The multiplier is a variable control allowing frequency settings between fixed ranges. The ranges are as shown in Table 1.

### AMPLITUDE CONTROL

The Amplitude Control provides amplitude adjustment from near 0 to 3V or greater for both sine and triangle waveforms.

### ON/OFF SWITCH

The ON/OFF Switch turns the power to the FG-500 on or off.

### POWER JACK

This jack allows the FG-500 to be powered from an external power source of 9V to 18VDC. Putting a plug into the jack disconnects the internal 9V battery.

### OUTPUT TERMINAL

The output marked SINE/TRIANGLE provides the sine and triangle waveforms. The output marked SQUARE WAVE provides the square wave. The output marked GND provides the ground for all output waveforms.

# SCHEMATIC DIAGRAM

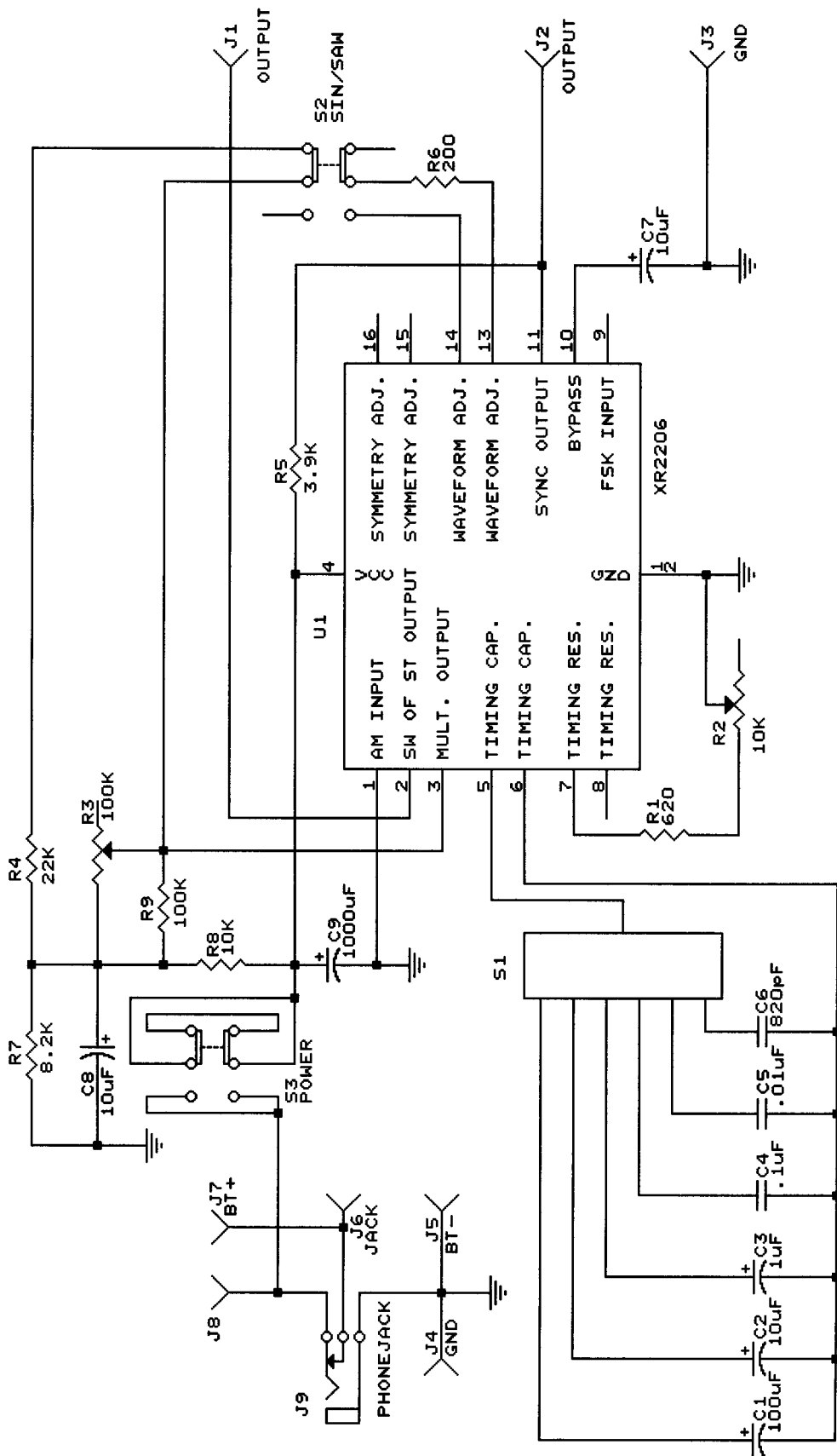

## QUIZ

- 1) The heart of the FG-500 Function Generator is the \_\_\_\_\_ monolithic function generator integrated circuit.
- 2) The XR-2206 is comprised of four main blocks. They are \_\_\_\_\_, \_\_\_\_\_, \_\_\_\_\_, and \_\_\_\_\_.
- 3) The VCO actually produces an output frequency proportional to an input \_\_\_\_\_.
- 4) The current switches route one of the currents to the VCO to produce an output \_\_\_\_\_.
- 5) The frequency is determined by the formula \_\_\_\_\_.
- 6) Frequency is inversely proportional to the value of \_\_\_\_\_.
- 7) The resistance between pins 13 and 14 determine the shape of the \_\_\_\_\_ wave on pin 2.
- 8) No resistor produces a \_\_\_\_\_ wave.
- 9) A  $200\Omega$  resistor produces a \_\_\_\_\_ wave.
- 10) The six ranges of frequency provided by the range switch are:  
\_\_\_\_\_ to \_\_\_\_\_.                      \_\_\_\_\_ to \_\_\_\_\_.  
\_\_\_\_\_ to \_\_\_\_\_.                      \_\_\_\_\_ to \_\_\_\_\_.  
\_\_\_\_\_ to \_\_\_\_\_.                      \_\_\_\_\_ to \_\_\_\_\_.

**Answers:** 1) XR-2206; 2) A Voltage Controlled Oscillator, An Analog Multiplier and Sine Shaper, Unity Gain Buffer Amplifier and A Set of Current Switches; 3) Current; 4) Frequency; 5)  $1/RC$ ; 6)  $1/RC$ ; 7) output; 8) triangle; 9) sine; 10) 1Hz to 15Hz, 10Hz to 150Hz, 100Hz to 1.5kHz, 1kHz to 15kHz, 10kHz to 150kHz, 100kHz to 1MHz.

***EMPTY PAGE***

**Elenco Electronics, Inc.**

150 W. Carpenter Avenue

Wheeling, IL 60090

(847) 541-3800

<http://www.elenco.com>

e-mail: [elenco@elenco.com](mailto:elenco@elenco.com)